

JOSKIN

www.joskin.com

AQUATRANS

WATER BOWSERS PERFECTLY
ADAPTED TO YOUR ANIMALS

WATER BOWSERS ACTION
- € 175/m³

Offer valid until 30.10.2024. Offer subject to conditions.



An easy and effective way of ensuring access to water for your animals

AQUATRANS

- 2" 1/2 rear ball valve
- Drinking trough for 1 animal
- Hydraulic brakes
- Jack stand
- 2" 1/2 dosable scatterer
- Air brakes
- Baffles in accordance with European standards
- 1/4-turn valve (2" 1/2)
- Hydraulic and air brakes
- Mudguards
- Side marker lights
- Rear or side bumpers
- Space for registration plate with lighting

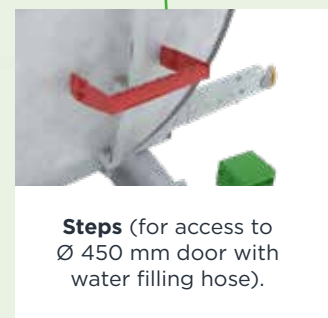
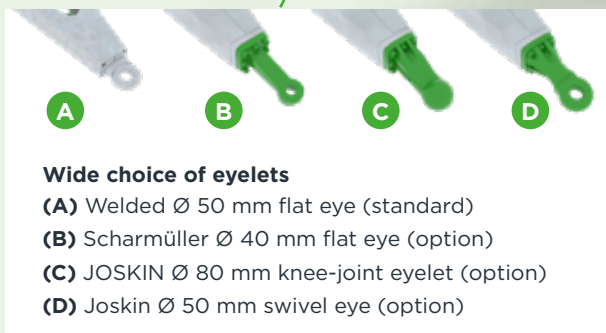
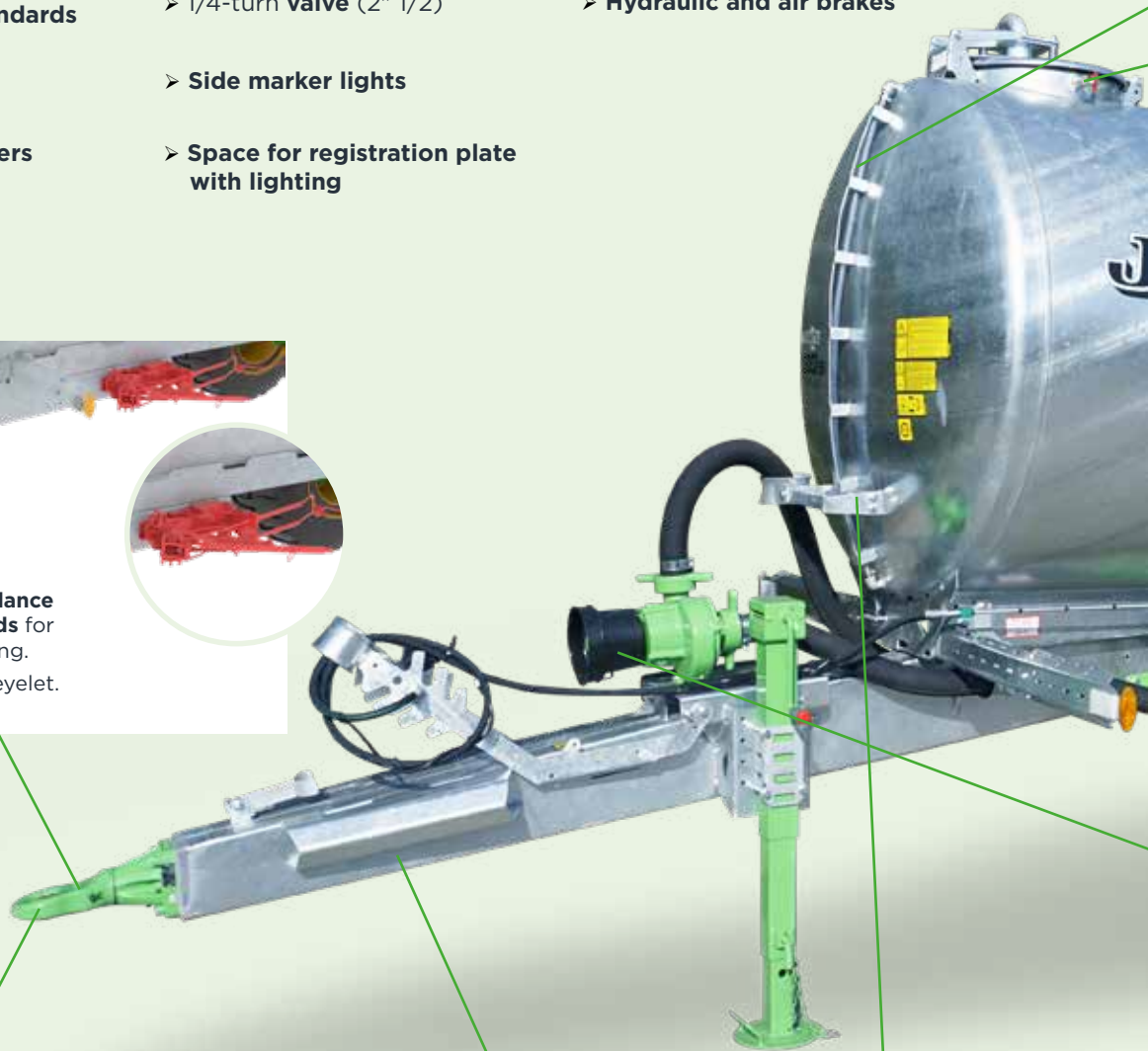



Protected **level indicator**, out of reach of animals.



Ø 450 mm **lid** with quick opening and seal.



Delivered as an unassembled kit to reduce transport costs and size.



70 l drinking trough with constant level with 1" valve (for closure during transport), in rear or side position.



Hinged rear lights, which can be folded manually to prevent damage by livestock.

(A) Centrifugal filling pump: 1,000 l/min flow, 540-rpm P.T.O. drive.



(B) 6 m, Ø 60 mm suction hose with non-return valve and pit bottom spacer.



Electric drainage pump (12 V) - including gun, counter and 4 m of 1" hose.

AQUATRANS RANGE

FROM 1,100 L TO 10,000 L

Static tanks	(identical tanks)	Mobile tanks	
<p>5,100 l Ø 1.25 m</p>		<p>5,100 l Ø 1.25 m</p>	<h3>AQUATRANS</h3> <ul style="list-style-type: none"> ✓ Capacity from 1,100 to 5,100 l ✓ Tank length from 1.56 to 4.35 m ✓ Diameter from 1 to 1.25 m ✓ Tank in galvanised high tensile steel ✓ Low empty weight
<p>4,300 l Ø 1.25 m</p>		<p>4,300 l Ø 1.25 m</p>	
<p>3,600 l Ø 1.25 m</p>		<p>3,600 l Ø 1.25 m</p>	
<p>2,100 l Ø 1 m</p>		<p>2,100 l Ø 1 m</p>	
<p>1,100 l Ø 1 m</p>		<p>1,100 l Ø 1 m</p>	
			<h3>AQUATRANS XL</h3> <ul style="list-style-type: none"> ✓ Capacity from 6,000 to 10,000 l ✓ Tank length from 4.12 to 4.88 m ✓ Diameter from 1.4 to 1.7 m ✓ Tank in galvanised high tensile steel ✓ Reinforced self-supporting structure
			<p>10,000 l Ø 1.7 m</p>
<h3>Mobile XL tanks</h3>			
<p>6,000 l Ø 1.4 m</p>	<p>7,000 l Ø 1.5 m</p>	<p>8,400 l Ø 1.5 m</p>	

